

Product Change Notification

Document No

PCN-A-1050804

Revision

1.0

PCN Topic:

Physical design of the Vehicle Dock for M9020 and M9020B has been changed.

Introduction:

To improve the performance and reliability, the Vehicle Dock of M9020 and M9020B has been changed. The physical design of the dock has been modified, thus allowing the unit (tablet and dock) to be mounted steadily on the vehicle. The AMPS holes on the dock also have been changed from M4 screw holes to M5 screw holes and some parts of the new docking is using metal. This modification allows using the unit in a highly shock/vibration environment without getting loose.

Please note that the new dock works with old units

Details:

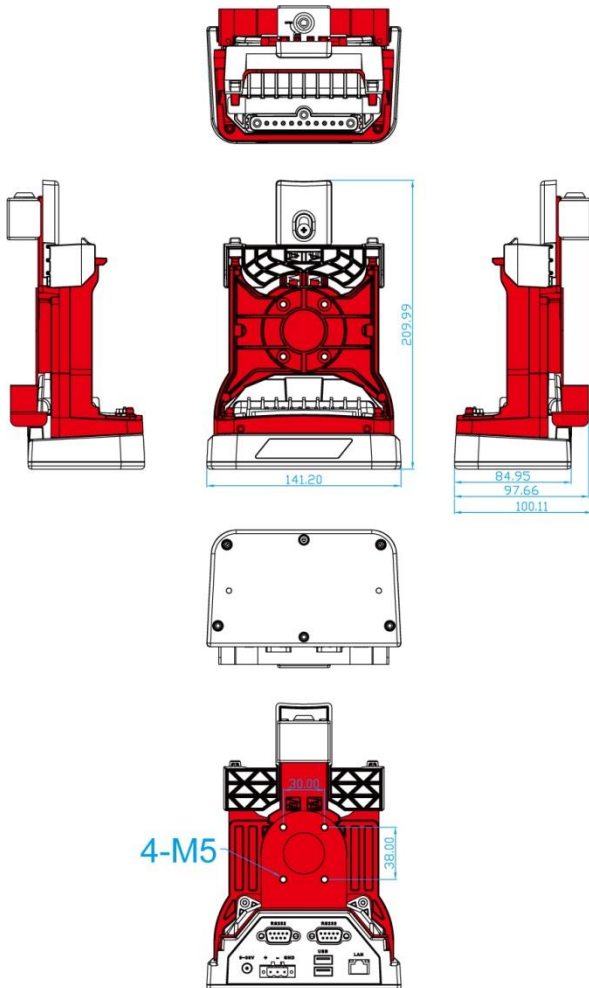
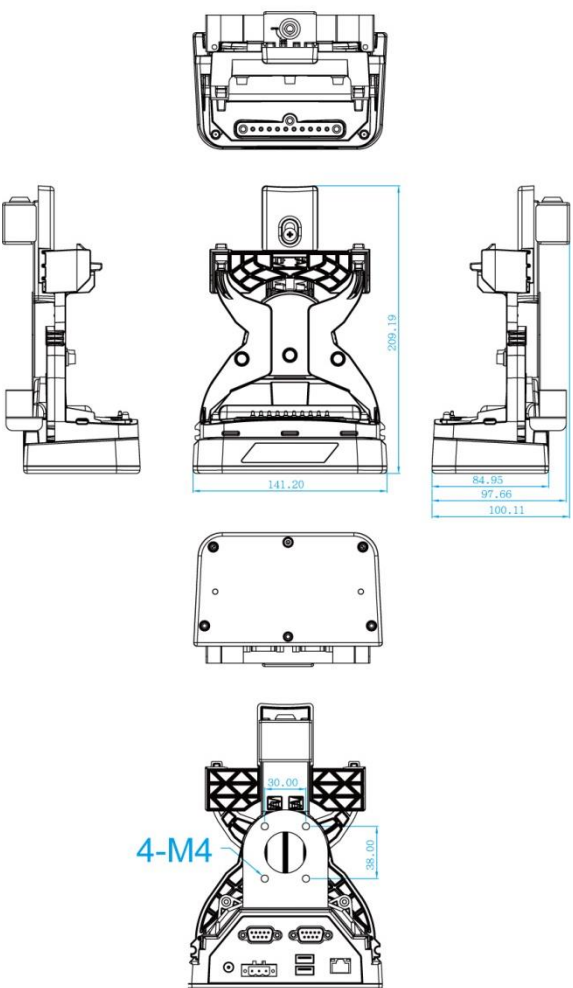
New Vehicle Dock for M9020 and M9020B	Original Vehicle Dock for M9020 and M9020B
<p><i>line drawing of the new dock:</i></p>  <p>Improvements of the new dock:</p> <ul style="list-style-type: none"> • Metal frame on some of the parts of the dock (color in red) • M5 x 4 screw holes • USB 2.0 Connectors 	<p><i>line drawing of the old dock:</i></p>  <p>Old dock:</p> <ul style="list-style-type: none"> • M4 x 4 screw holes • USB 1.1 Connectors

Picture of the new dock



Picture of the old dock



Change Date:

Aug-04-2016

Will be effective from Aug-04-2016

Issued by: Patrick Hsien

APPROVE:

[Handwritten Signature] **MD:**

EE:

TE:

PE: